

**Friction clutch press —
Determining the location of two-
hand controls**

**ÉTUDES ET
RECHERCHES**

Raymond Bélanger
Serge Massé
Réal Bourbonnière
Chantal Tellier
Christian Sirard

March 2000

RG-236

TECHNICAL GUIDE

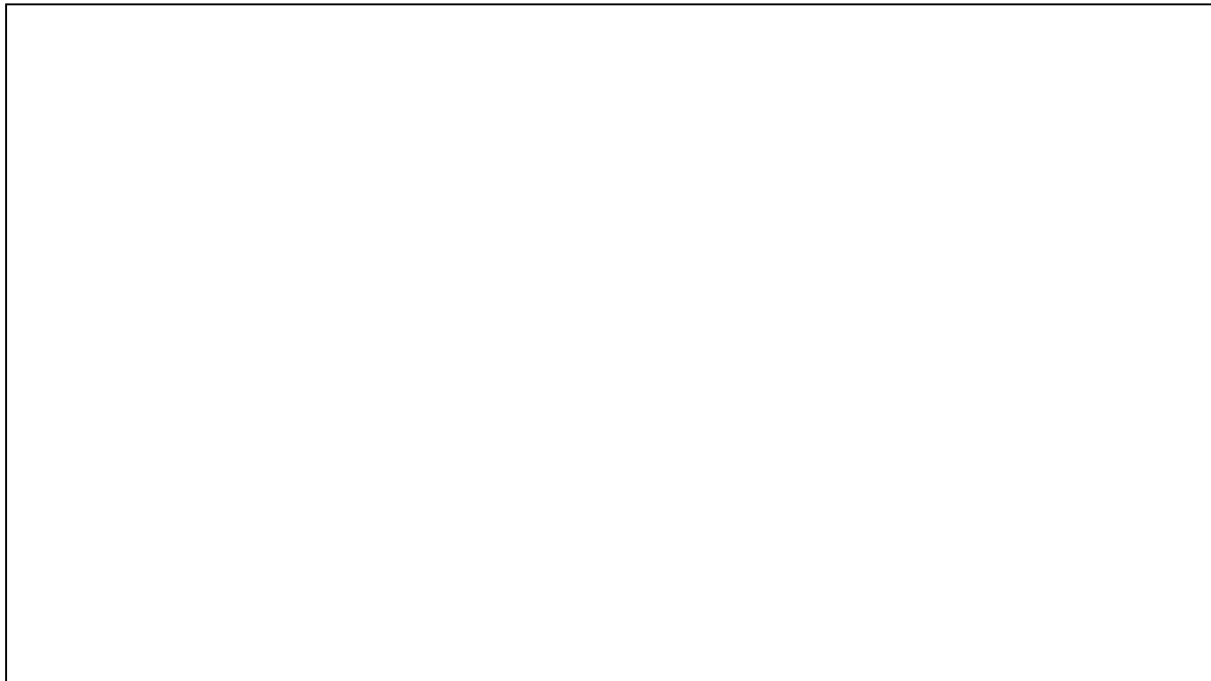

IRSST
Institut de recherche
en santé et en sécurité
du travail du Québec

WARNING

The purpose of this technical guide is to make it easier to determine the location of two-hand controls on a press with a friction clutch.

Two-hand controls increase the operating safety of metal presses by requiring the use of both hands to activate the controls and by distancing the control components from the metal forming zone, which is the machine's *danger zone*.

However, it is important to understand that protection by distancing the controls from the danger zone of the press is not, in itself, a guarantee of operator safety.

In fact, this method of protection in no way prevents physical access to the danger zone if, for example, there is a change in the parameters that were used to position the two-hand controls; the same is true for failure of a mechanical component of the press (for example, the brakes) or of the controls themselves. Finally, it also does not prevent repetition of the press cycle.

PREFACE

The purpose of this guide is to improve the comfort and safety conditions of metal press operators using two-hand controls. It has been produced by taking into account the needs of the different players (inspectors, researchers, etc.) in occupational health and safety (OHS) in the field of metal presses. This guide is therefore intended for the following people in particular: those in charge of OHS in companies using metal presses, metal press die setters and mechanics, participants and advisors from joint sector-based associations, workers' compensation board inspectors, and suppliers and manufacturers of metal presses and two-hand controls.

For two-hand controls, the Canadian standard on metal presses CAN/CSA-Z142-M90 states in article 9.5.1. a) that “*Each two-hand control shall require the **concurrent** use of both hands of the operator on the controls to actuate the press*”. The notion of concurrence referred to here implies that both hands must be on the buttons at the same time so that the initiation signal can be transmitted to the press. However, it does not specify any time between the activation of the buttons, which does not imply that the activation of the buttons is itself simultaneous. To correct the possible consequences of this implication, namely the depression of one of the buttons in the “operating” position so that the press can be controlled with only one hand, article 9.5.3. requires that the control system have “*An anti-repeat feature, ie, the controls shall be of a type that requires the release of both hand controls before the press can be actuated for a succeeding stroke. (...)*”. This control initialization eliminates, for all practical purposes, the motivation to depress one of the buttons so that the press can be controlled with only one hand. However, the risk remains total for the FIRST cycle.

This problem was taken into account in European standard EN 574-1996, under the heading 5.7. *Synchronous actuation*, in particular in the two subarticles below:

- 5.7.1. *An output signal shall be generated only when both control actuating devices are actuated in a time which is less or equal to 0.5 s.*
- 5.7.3. *If the control actuating devices are not actuated synchronously the output signal shall be prevented and it shall be necessary to release both control actuating devices and to reapply both input signals.*

This is the approach that we recommend. In this guide, we therefore only consider synchronous two-hand controls.

It is important to note also that the Canadian standard on metal presses mentions no distance for two-hand controls, thus allowing the possibility of inadequate positioning, a generator of risks.

The other standards, namely American standard ANSI B11.1 and European standard EN 692, mention distances for all machine speeds but are very conservative on the hand speed to be used

as a basis for calculation. In addition, as in the Canadian standard, no standard proposes or mentions a method for measuring these *safety* distances. As a result, this document was written for the purpose of facilitating the determination of the location of two-hand controls on a friction clutch press, in order to increase operating safety.

Finally, as previously mentioned, since the distance of the controls from the danger zone alone cannot ensure worker safety, the expression *positioning distance* (of the controls) will be used instead of *safety distance*.

TABLE OF CONTENTS

	Page
WARNING	i
PREFACE.....	ii
DETERMINING THE LOCATION OF TWO-HAND CONTROLS ON A FRICTION CLUTCH PRESS.....	1
1. LOCATION OF TWO-HAND CONTROLS: PARAMETERS TO BE CONSIDERED.....	2
1.1. OPERATOR’S HAND SPEED (IN METRES/SECOND).....	2
1.2. SLIDE STOPPING TIME (IN MILLISECONDS).....	3
1.3. DANGER ZONE CLOSING TIME (IN MILLISECONDS)	4
2. CALCULATING THE CONTROL POSITIONING DISTANCE (D)	4
2.1. CALCULATING THE POSITIONING DISTANCE (D_s) BASED ON SLIDE STOPPING	5
2.2. CALCULATING THE CONTROL POSITIONING DISTANCE (D_c) BASED ON THE CLOSING OF THE DANGER ZONE ..	6
3. GRAPH OF THE LOCATION OF THE TWO-HAND CONTROLS.....	6
3.1. LOCATION OF TWO-HAND CONTROLS BASED ON THE SLIDE STOPPING TIME OR SLIDE CLOSING TIME	7
3.1.1. <i>Examples of the use of graph 1</i>	8
4. METHOD FOR MEASURING THE CONTROL POSITIONING DISTANCE (D).....	9
5. PARAMETERS OF AN IMPEDING DEVICE FOR THE TWO-HAND CONTROLS.....	10
APPENDIX 1.....	11

DETERMINING THE LOCATION OF TWO-HAND CONTROLS ON A FRICTION CLUTCH PRESS

The operating safety of a friction clutch press depends on many factors, most of which are intrinsic to the machine, such as the condition of the brakes, the presence of a safety valve, etc. One of the recommended means for reducing operating risks consists of distancing the controls from the danger zone^a and of requiring the operator to use both hands simultaneously to control the press cycle. Two-hand controls are therefore used to initiate the cycle. As its name indicates, this type of interface has two control components, which generally consist of mechanically activated buttons^b. These controls must be synchronous, meaning that the two buttons must be activated at the same time (within a very short period) for the cycle initiation command to be accepted (if necessary, review the PREFACE on this subject). In the case of a friction clutch press, the two-hand controls can be of the hold-to-run or tripping types.

When they are the hold-to-run type, they must be kept depressed as long as the slide has not reached the low point in its stroke. When they are the tripping type, they are then used only to initiate the cycle and do not initiate stopping when they are released.

These controls must be located far enough away so that if the operator suddenly removes his hands from the control buttons after a cycle initiation command has been given and moves them towards the danger zone, the slide has the time to stop (hold-to-run mode) or to reach the low point in its stroke (tripping mode). It is therefore thought that the faster the operator's hand speed, or the more uncertain the condition of the brakes, or the slower the rate of the press, the farther away the controls should be located from the forming zone.

The location of the two-hand controls on a friction clutch press therefore essentially depends on 3 parameters: the operator's hand speed, the slide stopping time, and the time that the slide takes to close the danger zone.

a The danger zone of a metal press is the metal forming zone located under the slide, between the dies. This zone is characterized by the presence of one or more potential pinch points which can injure workers.

b There are also capacitive type two-hand controls which are activated by slightly touching the control, as well as luminous type controls (visible or infrared light), which are activated by passing a hand through the light beam.

1. LOCATION OF TWO-HAND CONTROLS: PARAMETERS TO BE CONSIDERED

1.1. Operator's hand speed (in metres/second)

A metal press operator's hand speed is strongly related to the location of the two-hand controls on the press. This location determines the path of the operator's hand as well as the speed that his hand could reach, particularly in the problem case of an incident recovery situation, commonly called *after reach* in this field. This situation implies a sudden and generally very rapid movement of the operator's hands towards the danger zone in order, for example, to correct the positioning of a piece of metal improperly placed between the dies before it is formed.

Three possibilities were considered:

1. The controls are located on the front of the press, at a level below the bed and parallel to it.

This location allows the slowest hand speed because it involves an upward movement of the arms and hands, meaning a movement against gravity.

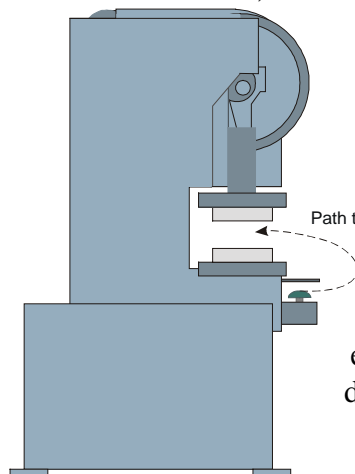

Figure 1

Depending on the characteristics of the press, in the case where the acceptable length of the path results in an unachievable location of the controls, the addition of an impeding device to hand movement, as for example a plate placed above the control buttons as illustrated in Figure 1, opposite, is then a possible solution. Such an impeding device, of sufficient width to prevent access to the buttons from the side (see section 5, page 10), requires that the first movement be backwards which, in addition to extending the path somewhat, slows the average speed of the hands during their movement.

Although offering an acceptable compromise regarding safety, this solution is not recommended for ergonomic reasons and must therefore be avoided as much as possible.

2. The controls are located on the front of the press, at a level above the slide and parallel to it.

This location allows a potentially higher hand speed than the previous location because it involves a downward movement of the arms and hands. Such a movement therefore takes advantage of gravity rather than having to overcome it.

3. The controls are placed on a mobile or fixed support, in front of the press, at a level below or even with the bed and generally perpendicular to it.

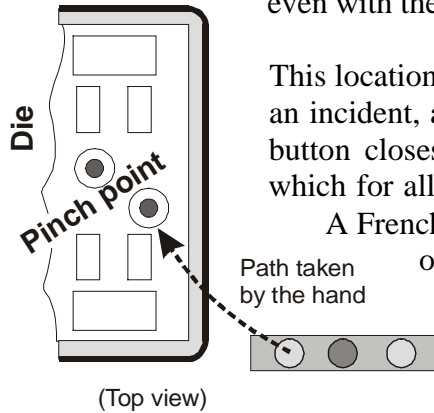

This location (illustrated in Figure 2, opposite) allows, in the event of an incident, a potentially very high speed for the hand placed on the button closest to the machine because it allows lateral movement, which for all practical purposes only involves the forearm and hand.

A French study by the I.N.R.S.^c has shown that with this path, an operator's hand could reach a speed of more than 6.0 m/s.

Figure 2

1.2. Slide stopping time (in milliseconds)

The slide stopping time T_s (stop initiated by the release of one of the *hold-to-run* type two-hand control buttons) depends on the following parameters:

T_{m_s} : time taken by the mechanical components, including the air valves to ensure stopping;

T_{tr_s} : time taken by the electrical components to transmit the stopping command;

T_{h_s} : reaction time for the two-hand control to initiate stopping.

therefore

$$T_s = T_{m_s} + T_{tr_s} + T_{h_s} \quad (1)$$

^c LIEVIN, D., KRAWSKY, G., MOUGEOT, B., SCHOULLER, J.F., *La sécurité dans un système opérateur-presses : étude du temps d'accès des mains à la zone dangereuse*, I.N.R.S., Vandoeuvre, France, Rapport N° 025/RE, Sept. 1973, 30 p. (Safety in an operator-press system: study of the danger-zone hand access time)

1.3. Danger zone closing time (in milliseconds)

The danger zone closing time^d T_c depends on the following parameters:

k: cycle time (T_c) multiplication factor, developed in the context of mechanical presses with a *full-revolution clutch*; it is equal to $(\frac{1}{2} + 1/N_p)$, where $\frac{1}{2}$ represents the half trajectory of the slide, and N_p the number of clutch engagement points. For a friction clutch press, this number of points is considered as infinite, and consequently $1/N_p = 0$. Therefore **k** is equal to $\frac{1}{2}$ cycle.

T_c: time for a complete cycle of the slide; this time, in milliseconds, is equal to $60 \times 1,000/C$, where **C** represents the rate of the press in cycles per minute. Therefore, $T_c = 60,000/C$ and $kT_c = 30,000/C$.

T_{m_c}: time taken by the mechanical components, including the air valves, to ensure closing;

T_{tr_c}: time taken by the electrical components to transmit the cycle initiation command;

T_{h_c}: reaction time of the two-hand control to initiate the cycle.

therefore
$$T_c = 30,000/C + (T_{m_c} + T_{tr_c} + T_{h_c}) \quad (2)$$

2. CALCULATING THE CONTROL POSITIONING DISTANCE (D)

As previously mentioned, on a friction clutch press, the control safety-distance is based either on the slide stopping, or on the closing of the danger zone by the slide when it reaches the low point in its stroke. The result is two ways of determining the control *positioning distance D* by calculation, based on the slide stopping time or the slide closing time respectively.

Since the standards say nothing about the significance of this distance, which determines the location of the two-hand controls, we have assimilated it, from a concern for safety, into the length of the path taken by the operator's hands. The method for measuring this distance is explained in section 4, page 9.

^d This is therefore equal to the time required for the slide to reach the low point in its stroke.

2.1. Calculating the positioning distance (D_s) based on slide stopping

When based on slide stopping, the *positioning distance* D_s of the controls is calculated from the slide stopping time T_s , as defined in equation (1), and from the operator's *hand speed* S_h , which can vary from 1.6 m/s^e to 6.0 m/s, as shown by the I.N.R.S. study, mentioned previously.

therefore
$$D_s = S_h \times (Tm_s + Ttr_s + Th_s) \quad (3)$$

The stopping time T_s , meaning the overall value of the parameters Tm_s (activation time for the mechanical components of the press to ensure stopping), Ttr_s (stopping command transmission time), and Th_s (reaction time for the two-hand control to initiate stopping), is measured using a device provided for this purpose.

Furthermore, when the two-hand control is already installed on the press, the control positioning distance D_s can then be measured, as indicated in section 4, page 9. A simple modification of equation (3) determines by calculation the maximum hand speed S_h allowed under these circumstances.

therefore
$$S_h = D_s \div (Tm_s + Ttr_s + Th_s) \quad (4)$$

^e The speed of 1.6 m/s was determined by I.O. LÖBL, during a study in 1935. This value has been retained in the American ANSI standard (the Canadian standard still does not have any).

2.2. Calculating the control positioning distance (D_c) based on the closing of the danger zone

When based on the closing of the danger zone by the slide, the control *positioning distance* D_c is calculated from the slide closing time T_c , as defined in equation (2), and from the *hand speed* S_h , which can vary from 1.6 m/s to 6.0 m/s. As with the stopping time, the closing time is measured using the device previously mentioned.

therefore
$$D_c = S_h \times [(30,000 \div C) + (T_{m_c} + T_{tr_c} + T_{h_c})] \quad (5)$$

As mentioned in the previous section, when the two-hand control is already installed on the press, the control *positioning distance* D_c can then be measured as indicated in section 4, page 9. A simple modification to equation (5) then determines the maximum hand speed S_h permitted under these circumstances.

therefore
$$S_h = D_c \div [(30,000 \div C) + (T_{m_c} + T_{tr_c} + T_{h_c})] \quad (6)$$

3. GRAPH OF THE LOCATION OF THE TWO-HAND CONTROLS

To make it easier to identify the location for the two-hand controls that can improve the operating safety of friction clutch presses, a graph was developed from the previous calculation formulas. With a little practice, this graph is easy to consult and to use, without prior calculations. With it, the optimum location of the two-hand controls in relation to the targeted potential degree of safety can be determined. Conversely, it illustrates, once the location of the two-hand controls has been determined, the safety zones that can be expected as long as the parameters used in the calculations, namely the stopping time (for a *hold-to-run* control) or the closing time of the slide when it reaches the low point in its stroke (for a *tripping* type control), remain unchanged.

3.1. Location of two-hand controls based on the slide stopping time or slide closing time

Graph 1, *Location of two-hand controls on a friction clutch press, based on the slide stopping time or slide closing time*, presents four zones determined from the possible combinations of operator hand speeds and slide stopping and slide closing times (a full page graph is also presented in Appendix 1). Zone no. 0 illustrates a situation in which no location of the two-hand controls is acceptable as a means of prevention. The three other zones, zones nos. 1, 2 and 3, refer respectively to the locations of two-hand controls for increasingly rapid hand speeds. As a result, these zones correspond to increasingly large positioning distances, for a given slide stopping or slide closing time. The border between zones nos. 0 and 1 corresponds to the specifications of the American ANSI standard, namely a hand speed of 1.6 m/s. Canadian standard CAN/CSA Z142-M90 on metal presses does not mention any hand speed.

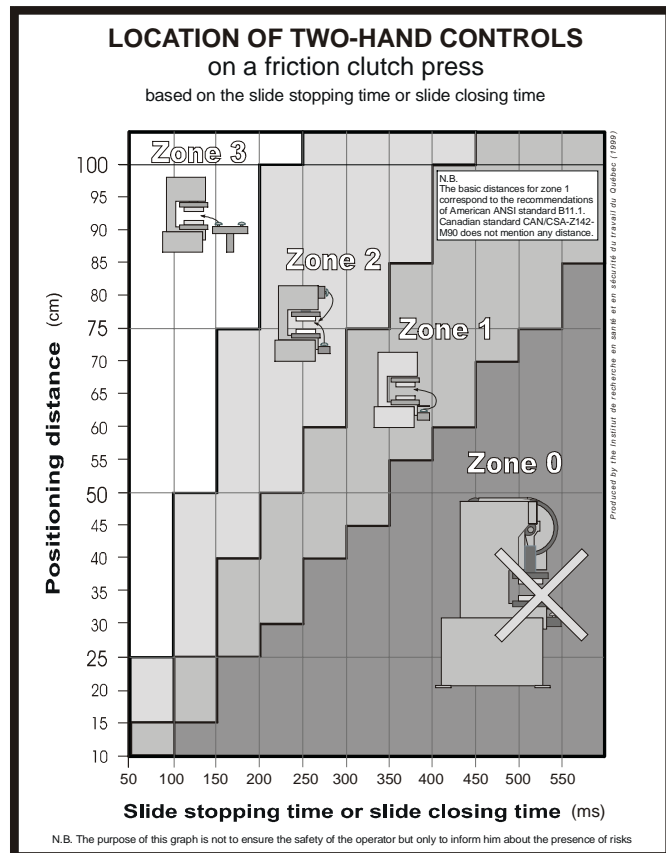

Graph 1

The possible hand speed was determined in relation to the path covered. Zone no. 1 refers to the control location on the front of the machine, below bed level. Also, the two-hand control buttons are covered by an impeding device which, in addition to lengthening the path of the operator's hands, has the main function of slowing the average hand speed by requiring an initial movement backwards (the parameters to be considered in obtaining an impeding device of appropriate dimensions are specified in section 5, page 10). Zone no. 2 refers to the position of the two-hand controls above the slide, as well as the position in zone no. 1 without an impeding device above the buttons. These locations allow faster hand speeds than those in zone no. 1, and therefore involve a greater positioning distance for the controls. Zone no. 3 refers to two-hand controls installed on a support located in front of the press and at a right angle to it. This latter location (see Figure 2, page 3) allows a faster hand speed for reaching the danger zone, and consequently increases the accident risk significantly. These various locations are clearly illustrated on the graph.

Finally, when circumstances allow, a greater safety margin can be obtained by increasing the positioning distance for a given location of the controls, since the length of the resulting path is itself increased. Of course, the location of the controls must be within with the operator's reach.

3.1.1. Examples of the use of graph 1

Two examples will help in understanding how to use graph 1, page 7

Example 1

Consider as a first example a friction clutch press whose slide stopping time (as defined in equation 1, page 3) is 150 milliseconds ($T_s = 150$ ms) and where the location of the *hold-to-run* type two-hand controls has not yet been determined.

The graph shows that, to fulfil the requirements inherent in zone no. 3, namely to install the two-hand controls on a support placed at a right angle to the machine (as illustrated on graph 1, page 7, and on Figure 2, page 3), the control positioning distance should then be equal to or greater than 75 cm. Furthermore, with a shorter distance (but longer than 40 cm), there is the choice of locating the controls at press bed level without an impeding device above the buttons, or above the slide (zone no. 2). Finally, if the circumstances (the dimensions of the die, for example allow only a positioning distance varying between 25 and 40 cm, the two-hand controls must then be located as specified for zone no. 1, meaning at a level below or equal with the bed of the press and covered by an impeding device above the control buttons, as illustrated on the graph and in section 5, page 10. Remember that this solution must be avoided as much as possible, due to the discomfort that it can cause the operator. Finally, within 25 cm, no acceptable location is possible, based on stopping of the slide. Means of protection such as guards must then be considered.

Example 2

In this example, consider that the two-hand controls are already installed on a friction clutch press. These controls are located above the slide, which corresponds to zone no. 2, and the positioning distance measured in relation to the pinch point is 50 cm.

Graph 1 on page 7 shows in this case that the slide stopping time must never exceed 250 ms. If the slide stopping time is between 250 and 350 ms, the controls must then be located at bed level (or lower) and covered by an impeding device, unless the press rate is sufficiently rapid to provide a closing time that allows the commands to be left at their present location. In this latter case, the two-hand controls will have to be the *tripping* type in order to prevent application of the brake if they are released.

4. METHOD FOR MEASURING THE CONTROL POSITIONING DISTANCE (D)

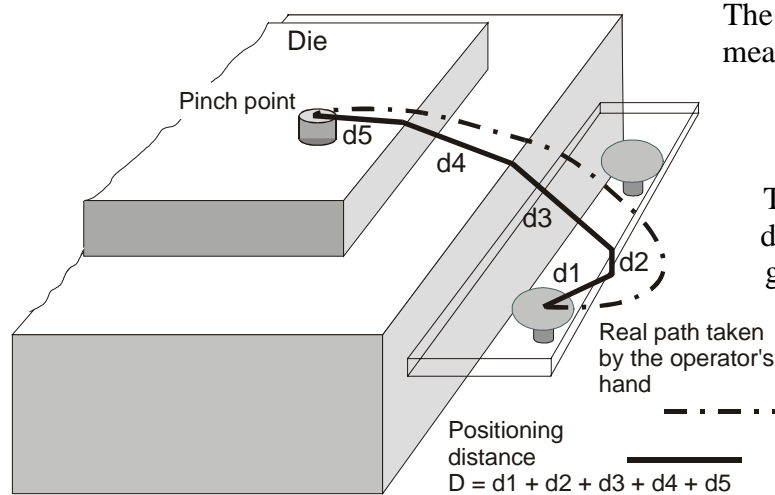

The control positioning distance **D** is measured using a flexible measuring tape. The measurement is taken between the pinch point and the top of the button closest to this point. The measuring tape measures the distances between the elements that it goes around, such as, in the example illustrated in Figure 3, the plate used as an impeding device (above the two-hand control buttons), the bed of the press, and the die. Each interval between these points is a

Figure 3
 distance **D** is then equal to the sum of these line segments.

line segment **d_i**. The control positioning

On the figure, note that the pinch point is shown to be inside the die; in fact, the edge of the die is generally the closest pinch point. In this case, the measurement is taken from this point. This distance is a rather good approximation of the shortest path that the operator's hand is likely to take during an attempt at incident recovery, as for example, to correct the position of a poorly placed piece of metal in the die, just prior to its forming.

Note that this positioning-distance measuring method increases the operator's safety margin due to the fact that the measured distance is slightly shorter than the real path of the operator's hands.

5. PARAMETERS OF AN IMPEDING DEVICE FOR THE TWO-HAND CONTROLS

Figure 4, opposite, shows a two-hand control whose buttons are covered with an impeding device. The diagram indicates the dimensions to be considered and how to measure them (in relation to the centre of the control buttons).

The purpose of an impeding device is to lengthen the path of the operator's hands when they move between the control buttons and the danger zone. The presence of the impeding device also reduces the average hand speed. Such an impeding device is required when the location of the two-hand controls must comply with zone no. 1, as indicated in graph 1.

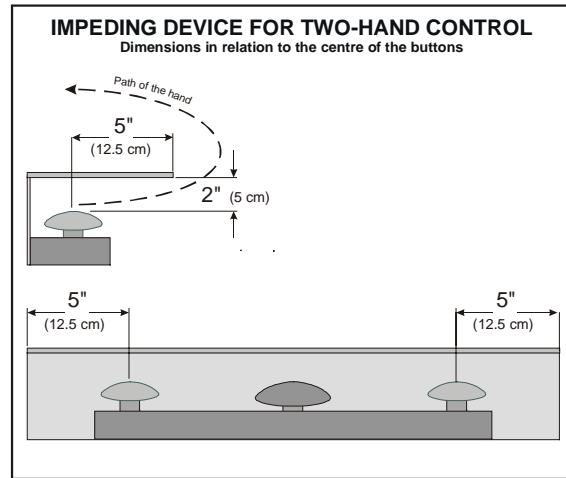
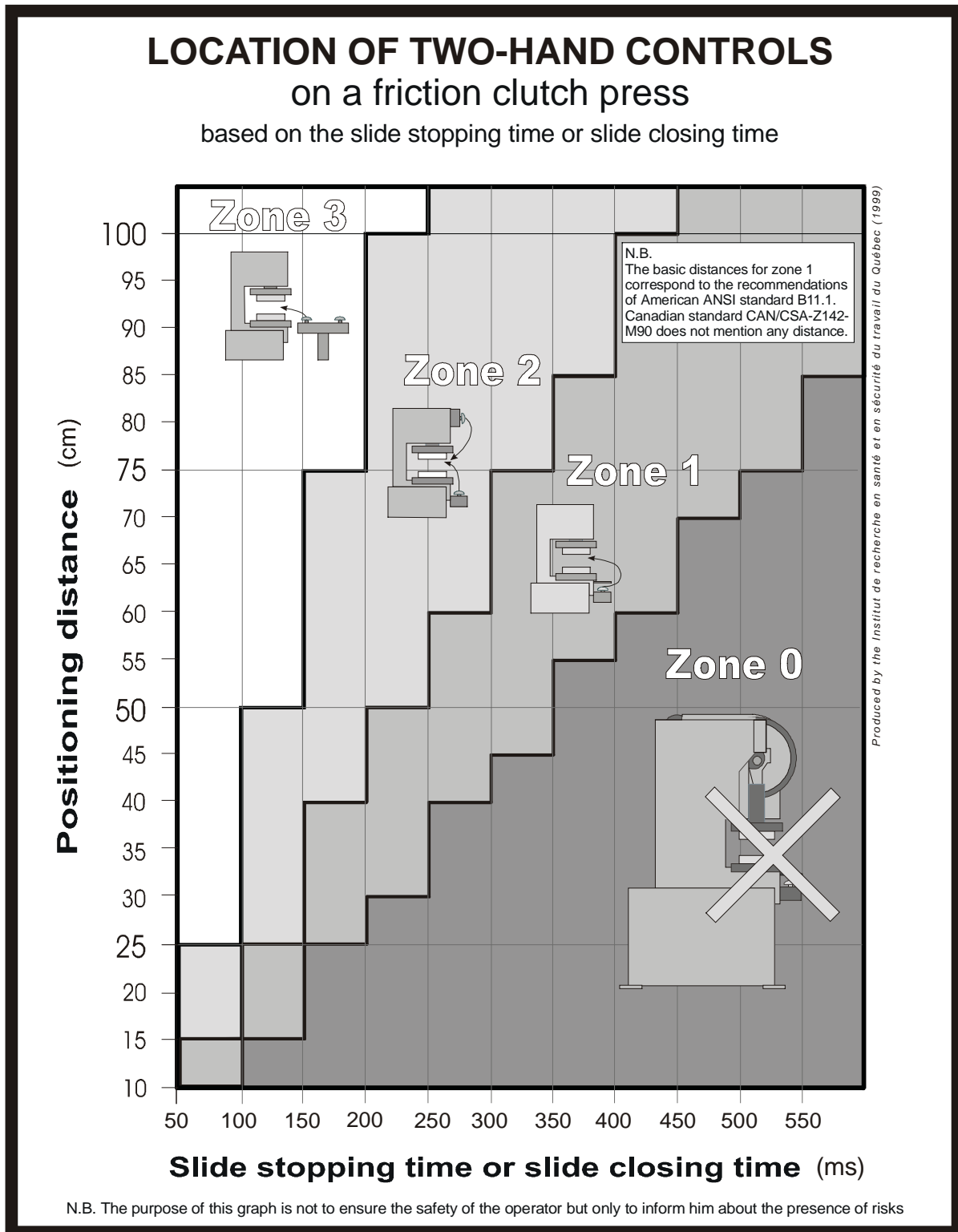

Figure 4

APPENDIX 1



LOCATION OF TWO-HAND CONTROLS on a friction clutch press

based on the slide stopping time or the slide closing time

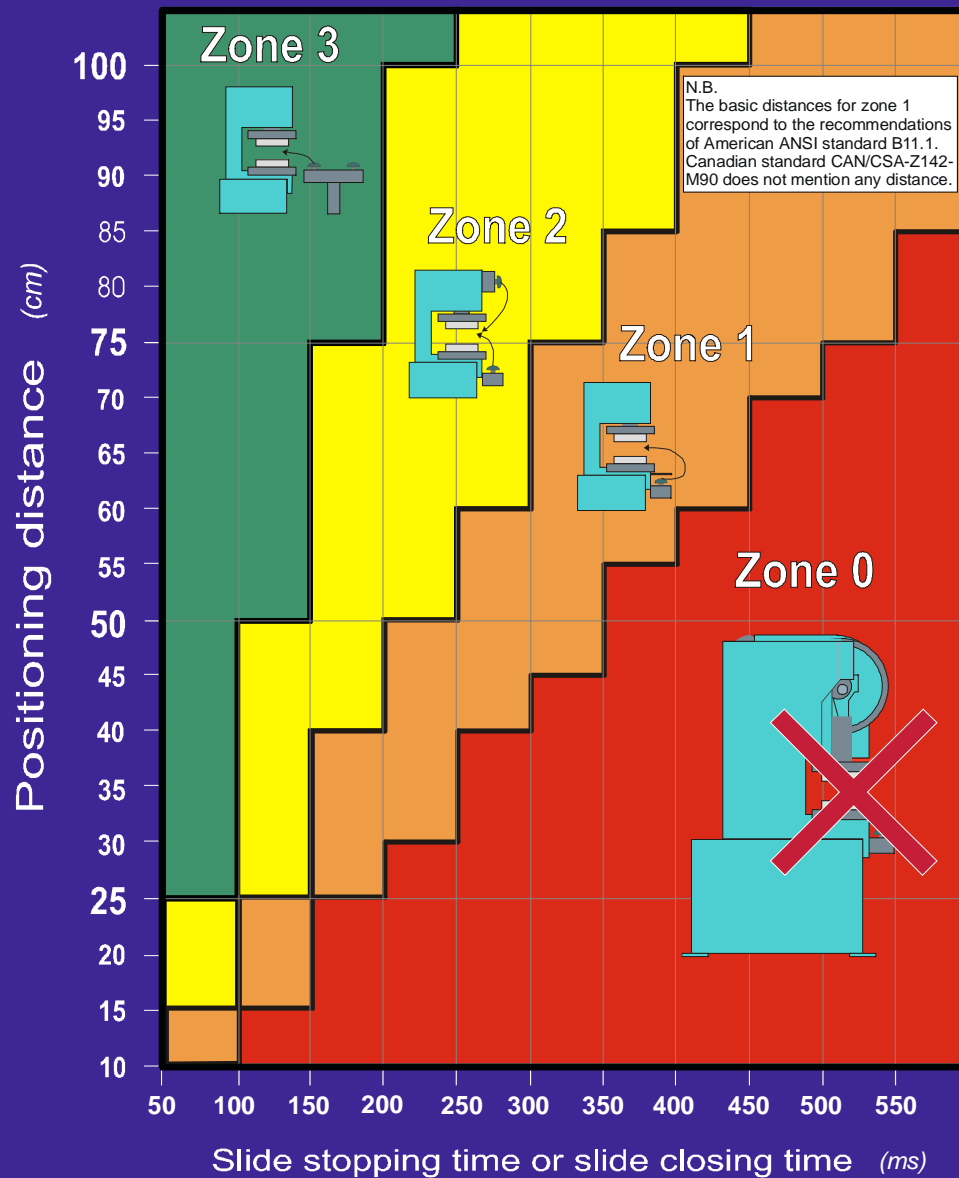

N.B. The purpose of this graph is not to ensure the safety of the operator but only to inform him about the presence of risks

EXAMPLES OF THE USE OF THE GRAPH

Example 1

Stopping / closing time = 160 ms

Location of controls

- Zone 1
- Zone 2
- Zone 3

Permissible positioning distances

- Zone 1: 25 cm or more
- Zone 2: 40 cm or more
- Zone 3: 75 cm or more

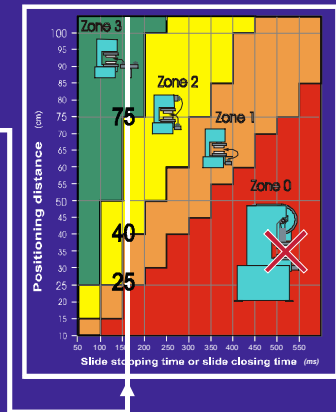

Example 2

Zone 2 type control

Measured distance = 50 cm

Maximum permissible

stopping / closing time = 250 ms

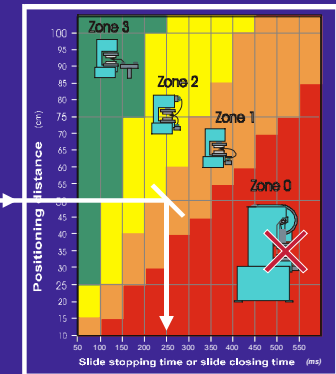

Example 3

Measuring the positioning distance of the two-hand controls

